

TRANSIT Ultimate

installation guide

2023-06-21 | v5.11 | Doc. no. 5481104

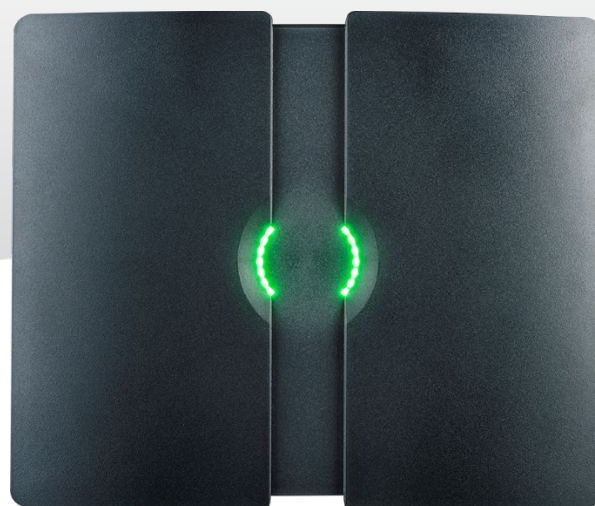

Copyright

Copyright © Nedap N.V. All rights reserved. The information in this document is subject to change without notice, it is not to be reproduced in any way, in whole or in part, without the written consent of Nedap N.V. All trademarks referenced belong to their respective owners

Disclaimer

Nedap N.V. has made every effort to ensure the accuracy of the information contained in this document. However, Nedap N.V. makes no representations or warranties whatsoever whether express or implied as to the accuracy, correctness, completeness or fit-for-purpose or suitability for the purpose of this product. You use the products at your own risk. Nedap N.V. excludes any liability to the maximum extent permitted by applicable law for the damages caused by errors or failures made during the installation or improper use of this product or by not applying the instructions stated in this document.

Nedap N.V. reserves the right to make improvements or amendments to this document and/or the products described therein at any time without any notification. The latest version of this document can be found on our partner portal <https://portal.nedapidentification.com>. Please download the latest version of this document and keep a copy for your own records.

This document can be published in various languages but only the English language version will prevail. Nedap N.V. assumes no responsibility for any errors caused for the translations into another language.

Warranty and spare parts

Please consult the Nedap products dealer from whom you purchased this product, in regards to the applicable warranty conditions. This product cannot be used for any other purpose as described in this document. If the product is not installed according to this document; the warranty provided is not applicable. At the sole discretion of Nedap N.V., Nedap N.V. may decide to change the conditions of the warranty policy. You agree that Nedap N.V. is able to compensate you the pro-rata value of the warranty involved rather than replacing or repairing the product depending on the technical or economical value of the product.

Prior to applying the warranty, please verify if you comply with the warranty conditions of the warranty policy, whether you can successfully apply for the replacement or repair of a defective part. Parts can only be replaced with original Nedap parts, otherwise the warranty policy will not be applicable on the product. If the warranty is applicable, please contact the dealer or send the defective parts to the dealer.

Additional information

For any information or questions regarding the product, please contact your own dealer

Nedap N.V.
Identification Systems
Parallelweg 2
7141 DC Groenlo
The Netherlands

+31 (0)544 471 111
info@nedapidentification.com
www.nedapidentification.com

Contents

- 1 Introduction 5
 - 1.1 Product description..... 5
 - 1.2 Ultimate features 6
- 2 Installation 7
 - 2.1 Safety precautions 7
 - 2.2 Installation guidelines 7
 - 2.3 Mounting instructions 8
 - 2.3.1 TRANSIT Ultimate dimensions 8
 - 2.3.2 Wall mounting..... 9
 - 2.3.3 Pole mounting..... 10
 - 2.3.4 Weather protection hood 11
 - 2.4 Installing the security key pack 12
 - 2.5 Installing a communication board 13
- 3 OSDP Interface Board 14
 - 3.1 TRANSIT wiring 14
 - 3.2 RS485-OSDP wiring..... 15
 - 3.3 TRANSIT configuration 16
- 4 Connections 17
 - 4.1 Overview 17
 - 4.2 Power supply..... 18
 - 4.2.1 AC mains 18
 - 4.2.2 DC supply input..... 18
 - 4.2.3 DC output 19
 - 4.3 Communication 20
 - 4.3.1 USB..... 20
 - 4.3.2 Wiegand / Magstripe / Barcode 21
 - 4.3.3 RS232..... 22
 - 4.3.4 RS422-485 22
 - 4.4 Digital I/O 23
 - 4.4.1 Relay output..... 23
 - 4.4.2 Read disable input..... 24
 - 4.4.3 Tamper switch 25
 - 4.4.4 General purpose inputs..... 26
 - 4.5 Special connections 27

- 4.5.1 Proximity antenna 27
- 4.5.2 Nedap antenna modulation 28
- 5 Firmware update..... 29
- 6 Configuration..... 30
 - 6.1 Serial communication select..... 30
 - 6.2 Range beeper 30
 - 6.3 Ultimate mode..... 31
 - 6.4 Frequency select..... 32
 - 6.4.1 Frequency select display & buttons 32
 - 6.4.2 Frequency select dip-switches..... 32
 - 6.5 Read range control..... 33
 - 6.6 Microwave time-sharing..... 34
- 7 LED indications..... 35
 - 7.1 Main board LED indications 35
 - 7.2 TAB board LED indications 36
- A Technical specification 37
- B Frequency channels..... 38
- C Nedap part numbers..... 39
- D Disposal of equipment..... 40
- E CE / UKCA declaration 40
- F FCC / IC statement 40
- G Document revision 41

1 Introduction

1.1 Product description

The TRANSIT Ultimate is a long-range reader, based on semi active RFID technology, which enables automatic vehicle identification at distances of up to 15 meters (50 ft.)¹ and speeds of up to 200 km/h (125 mph).

Key features

- Robust industrial design
- Read range up to 15 meters [50 ft.]
- Object speed up to 200 km/h [125 mph]
- Adjustable read range
- Selectable frequency channels
- Variety of integrated communication interfaces
- 3 color LED indication
- Tag authentication based on AES encryption
- Backwards-compatible with previous TRANSIT readers.

Frequency channels

The TRANSIT Ultimate operates on a factory-set frequency channel. Different frequency channels allow multiple readers to operate in close vicinity of each other without interference.

Read range adjustment

The reader efficiently resolves typical multi-lane, entry and exit reader challenges. The read range of the TRANSIT Ultimate can be adjusted to offer secure and reliable identification in demanding applications.

Housing & mounting

The TRANSIT Ultimate is intended for outdoor installation.

The weatherproof TRANSIT Ultimate reader features an IP66 certified housing. The reader operates reliable under harsh environmental conditions and is able to withstand exposure to rain, snow and ice. Wall mounting equipment is included.

Interfaces & protocols

The TRANSIT Ultimate is designed for seamless and flexible integration into existing management systems in the industry, such as security, parking, and logistics. Several communication interfaces to the host system are available such as RS232, RS422, RS485 and TCP/IP. Also open industry-standards protocols such as OSDP, Wiegand, Magstripe and Barcode are available.

¹ When used with Window Button. The maximum read range depends on the identifier type, the installation and the environment

1.2 Ultimate features

Implementation

The Ultimate-mode features are implemented in the TAB board. The TAB-board performs the authentication and other Ultimate functions using the bi-directional tag communication channel at 433MHz.

The TAB functions are only performed when both antennas (433MHz and 2.45GHz) receive the same id-number. This ensures that the tag is in the well-defined directional beam in front of the reader.

Encrypted tag authentication

The TRANSIT Ultimate enables encrypted tag authentication for the Ultimate tags: Smartcard Booster Ultimate, LEGIC Booster Ultimate and Window Tag Ultimate. The authentication uses encryption based upon AES 128-bit keys. Key diversification is used to ensure that a unique encryption key is used for every tag.

Note

The secure authentication requires the Security Key Pack to be installed.

Smartcard-Booster End2End (HID SEOS)

Another Ultimate feature is the support for transparently reading contactless smartcards through the Smartcard-Booster End2End. This includes HID SEOS and iCLASS cards.

See for more details the Smartcard-Booster End2End application note.

Note

The Smartcard-Booster End2End with HID SEOS cards requires a TAB-board hardware revision C.

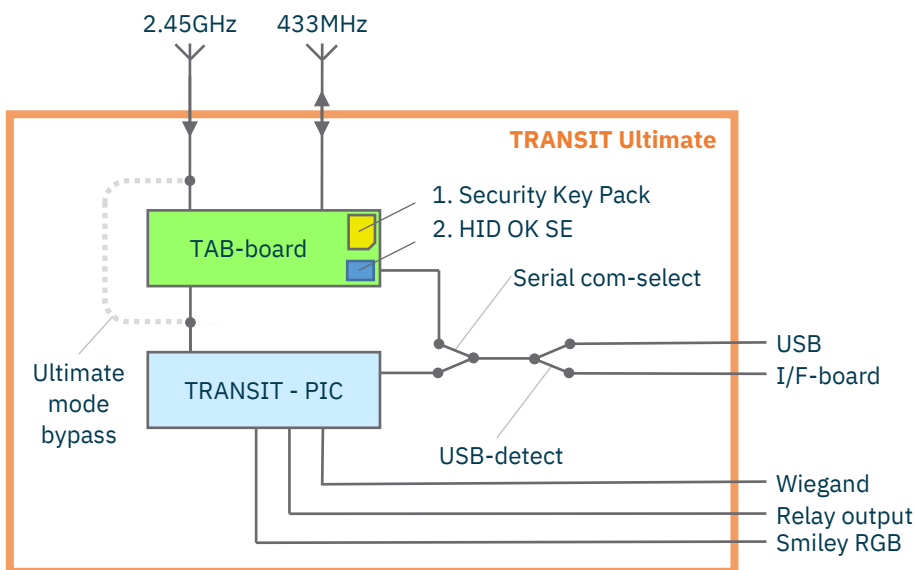

Figure 1: TRANSIT Ultimate block diagram

The TAB board may be bypassed to make the TRANSIT Ultimate backwards compatible with the TRANSIT Standard. See chapter 6.3.

2 Installation

2.1 Safety precautions

The following safety precautions should be observed during normal use, service and repair:

- The TRANSIT Ultimate shall be connected to safety ground.
- Disconnecting from (mains) power supply before removing any parts.
- The TRANSIT Ultimate shall only be installed and serviced by qualified service personnel.
- To be sure of safety, do not modify or add anything other than mentioned in this manual or indicated by NEDAP.

2.2 Installation guidelines

The TRANSIT Ultimate can be installed in any position. The normally expected read range is up to 10-15 meters. The hinges should be on top of the reader.

- The reader must be positioned correctly to achieve an optimal detection range.
- The tag must be in line-of-sight with the reader.
- RF interference of other equipment must be avoided.

Landscape installation – wide beam

Usually the reader is mounted in the horizontal position. In this case the coverage area in the horizontal plane is maximized. The horizontal beam is 80 degrees.

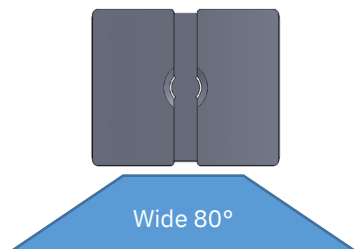

Portrait installation – narrow beam

In some applications a vertical installation is required to make use of the smaller beam width in the vertical plane. The vertical beam is 40 degrees. This can be very useful in multi-lane applications to prevent cross readings.

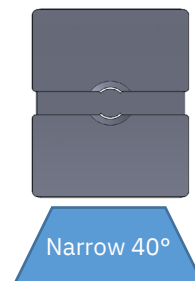

In applications where barriers are used, it is advisable to install the TRANSIT Ultimate at the secure side of the barrier. Below a typical TRANSIT Ultimate reader installation.

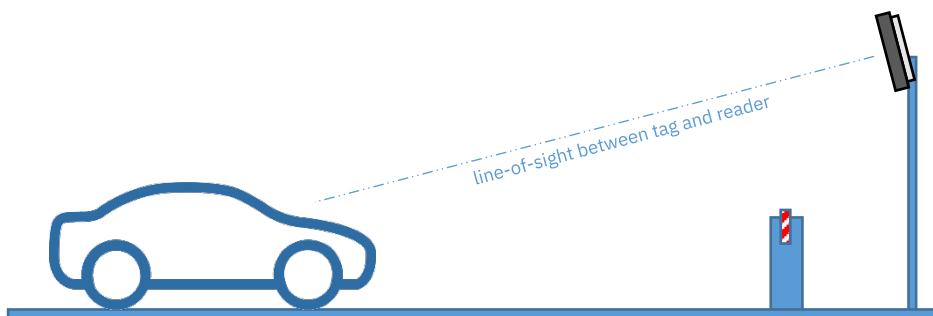

2.3 Mounting instructions

See the following chapters for details about the dimensions of the reader and the mounting brackets and the locations of the mounting positions.

2.3.1 TRANSIT Ultimate dimensions

The picture below shows the dimensions of the TRANSIT Ultimate.
All dimensions are in mm.

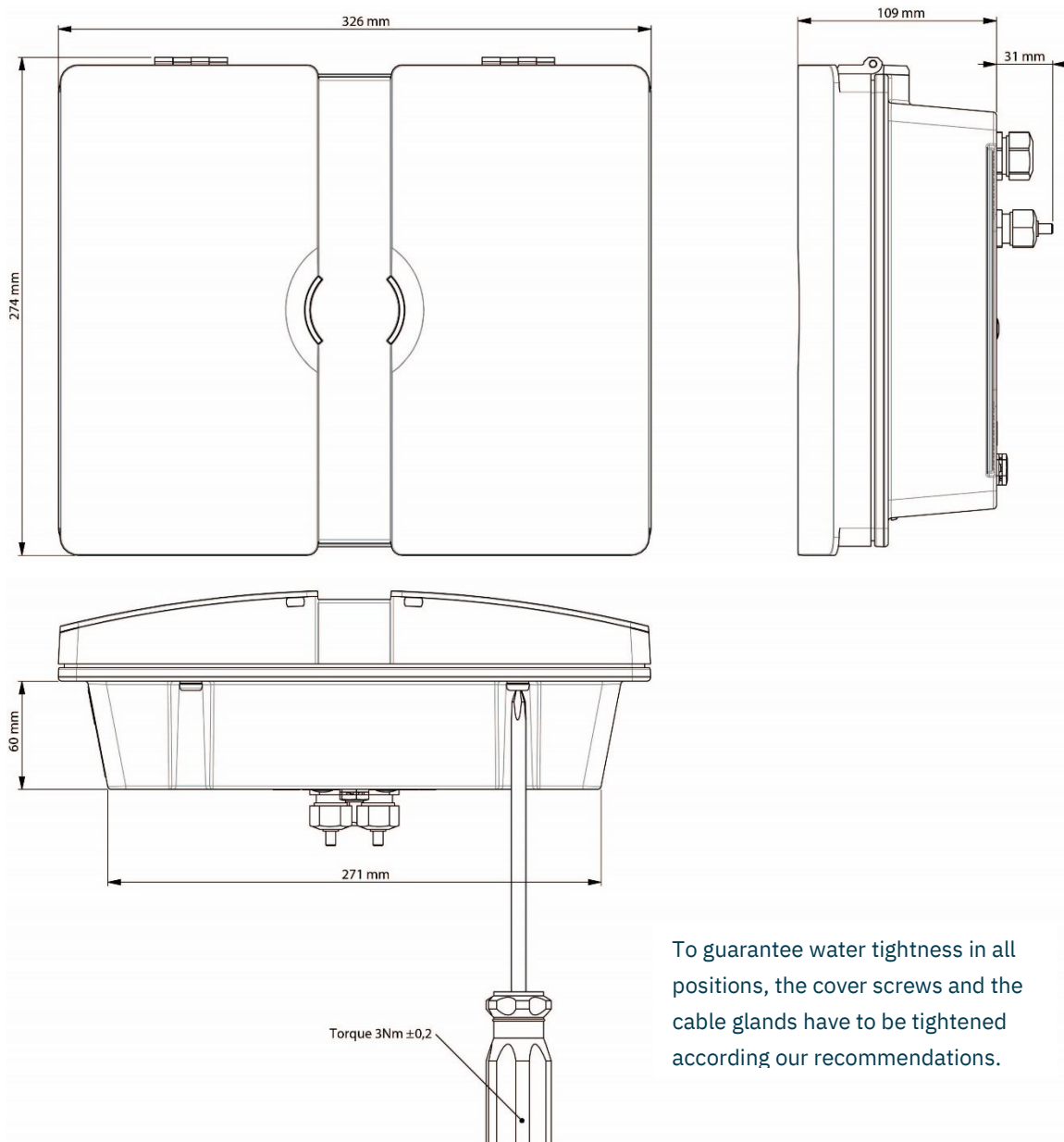

To guarantee water tightness in all positions, the cover screws and the cable glands have to be tightened according our recommendations.

Figure 2: Dimensions TRANSIT Ultimate

2.3.2 Wall mounting

The Wall Mounting Set is supplied with the TRANSIT Ultimate reader. When the Wall Mounting Set is assembled mount it to the wall (or to the Pole Mounting Set) based on the dimensions in Figure 3. The TRANSIT Ultimate can be “aimed” with the Wall Mounting Set and when the bolts are tightened, it will stay in place.

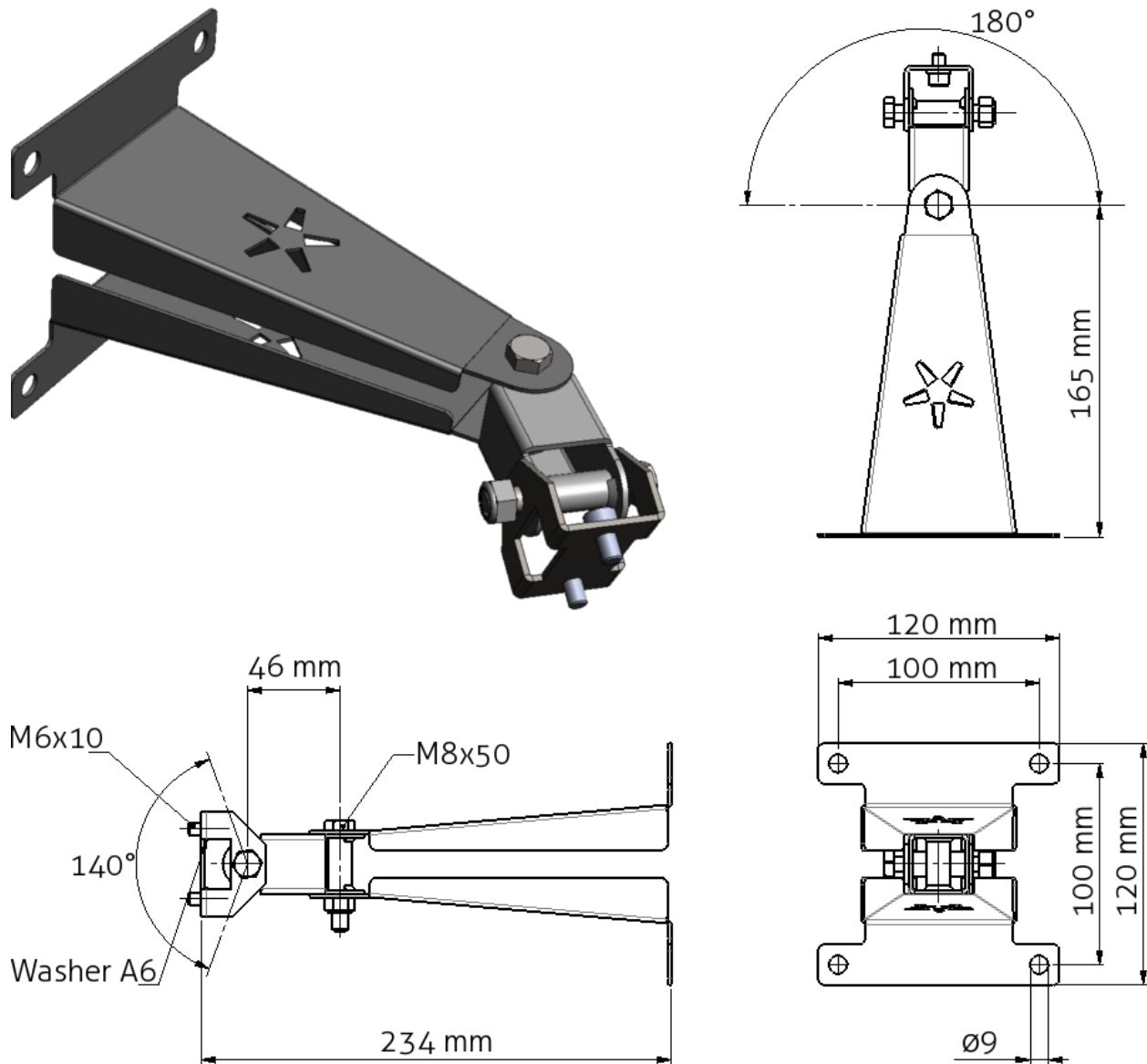

Figure 3: Wall Mounting Set

2.3.3 Pole mounting

The TRANSIT Ultimate can be mounted to round poles with maximum diameter of 190 mm and square poles with maximum diameter of 150 mm using the Pole Mounting Kit.

The Pole Mounting Kit must be ordered separately (art. no. 5626595).

The Wall Mounting Set will be mounted onto the Pole Mounting Kit.

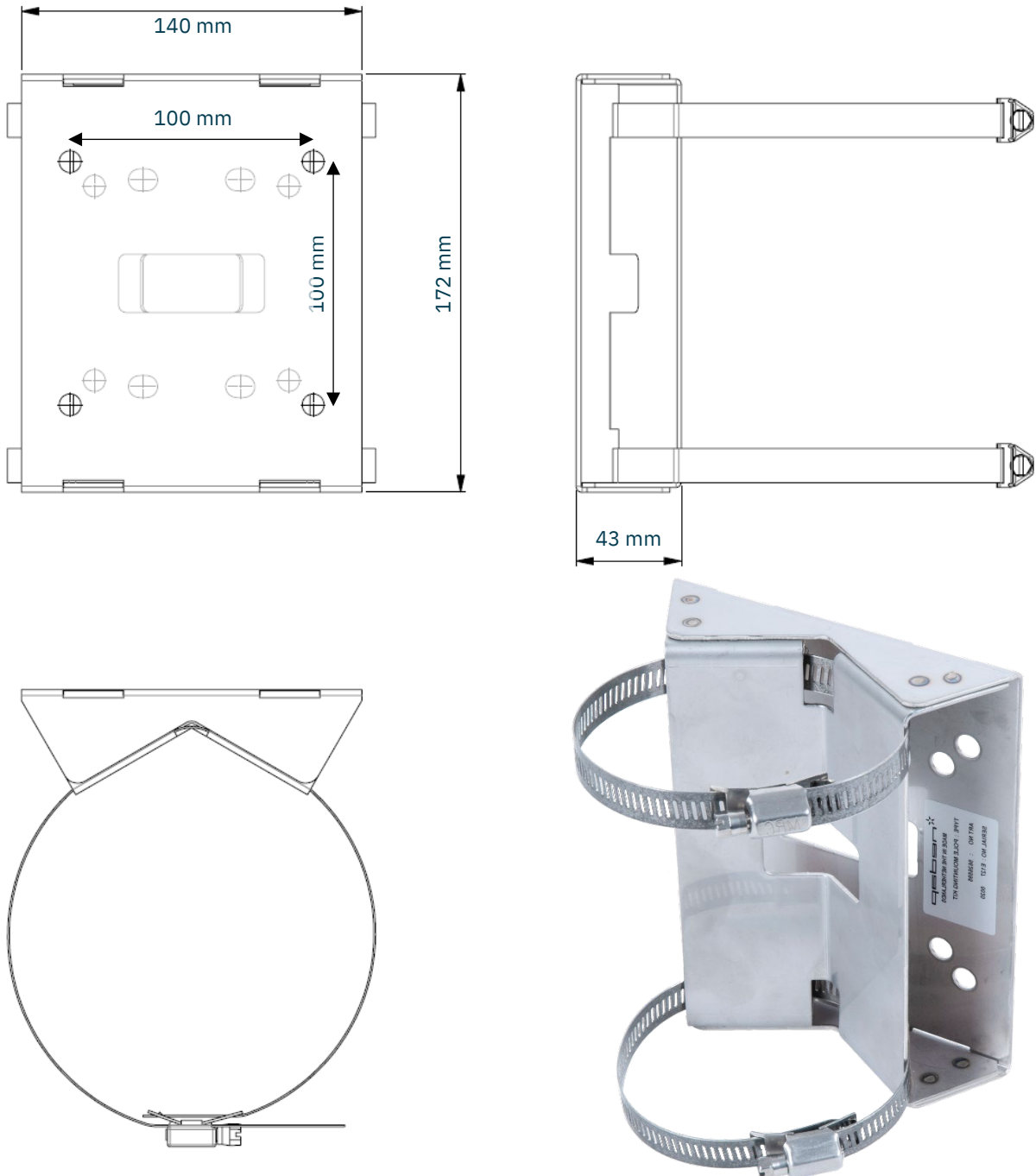

Figure 4: Dimensions Pole Mounting Kit

2.3.4 Weather protection hood

The Weather Protection hood is recommended when the reader is installed in direct sunlight.
The Weather Protection Hood must be ordered separately (art. no. 9218327).

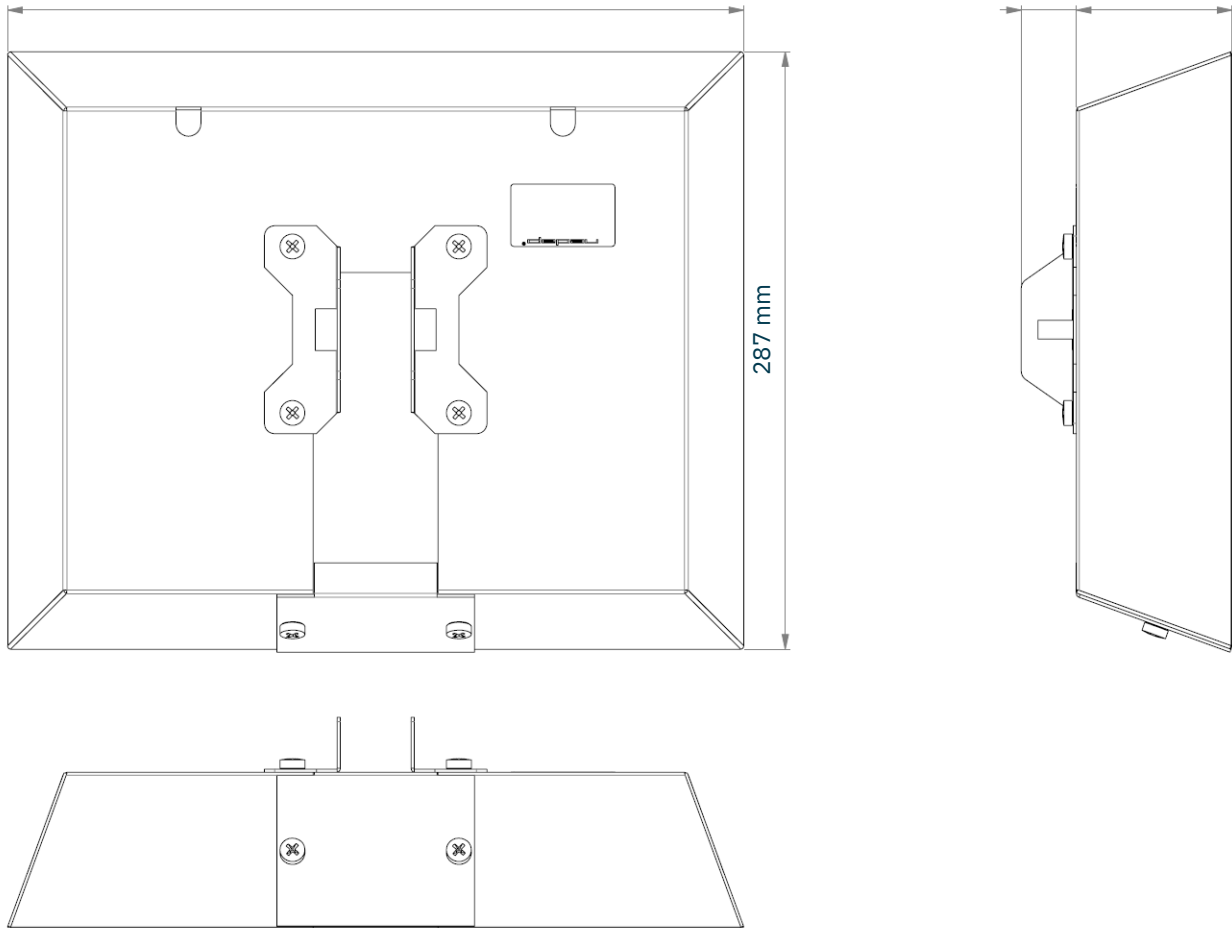

Figure 5: Dimensions Weather Protection Hood

2.4 Installing the security key pack

The optional Security Key Pack (SAM) must be ordered separately (art. no. 9216537) and is required for the TRANSIT Ultimate to perform the encrypted authentication on the Ultimate tags. Please follow the procedure below to install the Security Key Pack into the TRANSIT Ultimate.

Security Key Pack installation procedure

Insert the Security Key Pack (SAM) into the TAB board.

1. Align the notch as indicated in Figure 6 and keep the metal contacts backwards.
2. Push the SAM into the slot until it clicks into place.
3. Enable the Ultimate-mode by setting dip-switch SW2-2 ON. See chapter 6.3.

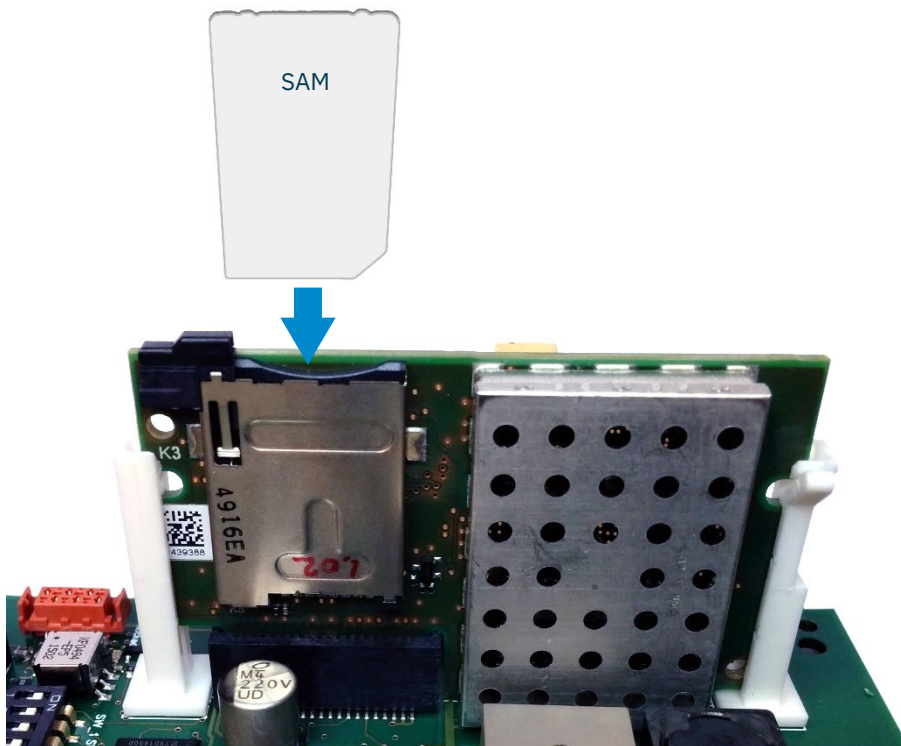

Figure 6: Installing the Security Key Pack (SAM)

Note

The presence of the LOCK switch on the TAB board indicates the hardware revision.



✓ TAB board hardware revision C

Supports Smartcard-Booster Ultimate
Supports Smartcard-Booster End2End (SEOS)



✗ Older TAB

Supports Smartcard-Booster Ultimate

2.5 Installing a communication board

The TRANSIT Ultimate features an on-board USB port and a Wiegand / Magstripe / Barcode interface. See chapter 4.3 for more details.

Other communication interfaces can modularly be installed in the reader by means of a communication interface board. There are various communication interface boards available for the TRANSIT Ultimate. See appendix C for available boards and their part numbers.

Make sure to follow all safety precautions outlined in chapter 2.1 when installing or replacing a communication board.

Communication board installation procedure:

1. Open the TRANSIT Ultimate. You can put the cover strut into place to keep the cover open.
2. Disconnect the power supply.
3. Place the communication interface board on the 14-pin header K5 as indicated in the picture below.
4. Make sure that the 4 plastic PCB supports are properly positioned and fixed into the communication board.
5. Read the communication board's installation guide for additional notes like address setting, jumper settings and wiring details.
6. Test if the communication works correctly.
7. Close the cover of the TRANSIT Ultimate.

PCC485/OSDP

The PCC485/OSDP converter board is not installed as described above.

Please refer to chapter 3 for more details.

3 OSDP Interface Board

For supporting OSDP on the TRANSIT Ultimate it is required to use the OSDP Interface Board, which includes the PCC485/OSDP converter. This board implements the OSDP protocol according to the SIA OSDP v2.1.7 standard, including the Secure Channel Protocol.

You may purchase the TRANSIT Ultimate together with the OSDP Installation Board. This is convenient, because then the board is already installed by Nedap. See appendix C for part numbers.

This chapter describes how to install the OSDP Interface Board afterwards yourselves. Make sure to follow all safety precautions outlined in chapter 2.1.

OSDP Interface Board installation procedure

1. Connect the OSDP Interface Board (PCC485) with TRANSIT as described in chapter 3.1.
2. Connect to the RS485-OSDP network as described in chapter 3.2.
3. Setup TRANSIT configuration as described in chapter 3.3.

3.1 TRANSIT wiring

The TRANSIT Ultimate and OSDP Interface Board must be connected as shown in the figure below. The wiring includes power supply, antenna signal for identification and control for relay output and front cover LED.

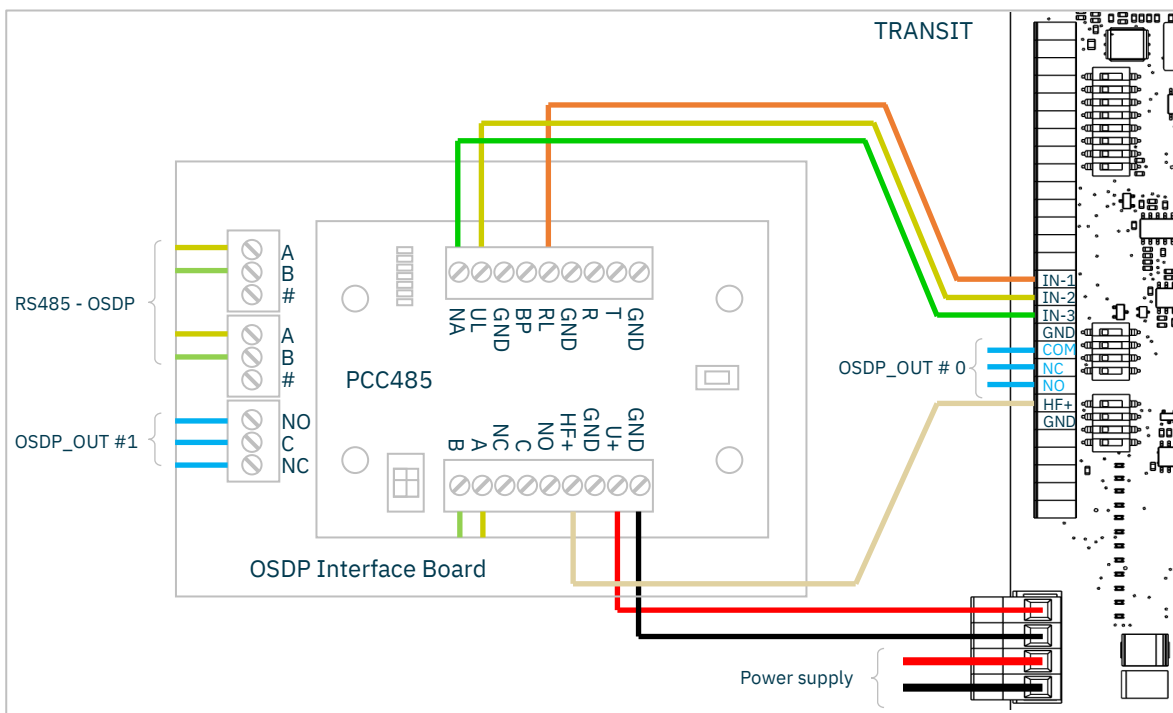

Figure 7: TRANSIT / OSDP Interface Board wiring

3.2 RS485-OSDP wiring

The RS485-OSDP wiring should be connected to the RS485 connections on the OSDP Installation Board (OSDP-IB) or directly to the PCC485. See wiring picture below.

For point-to-point communication enable the termination resistor. PCC485 switch 1 to ON position. See picture below.

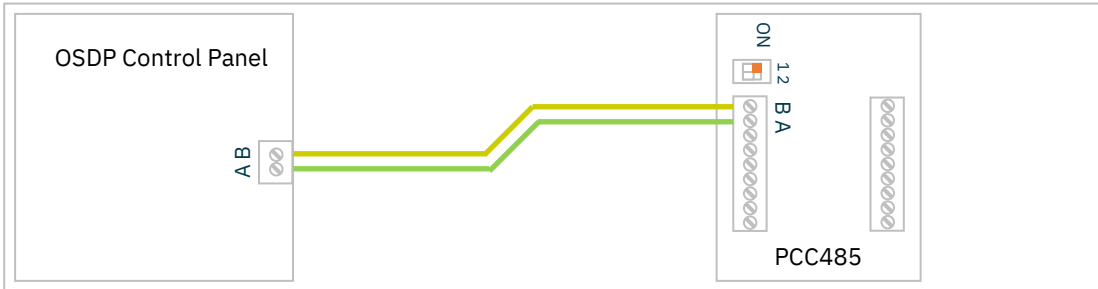

Figure 8: RS485-OSDP point-to-point wiring

For multi-drop communication disable the termination resistor on the PCC485 on all devices except the last device. The termination resistor should be enabled on the last device in a multi-drop communication system. See picture below.

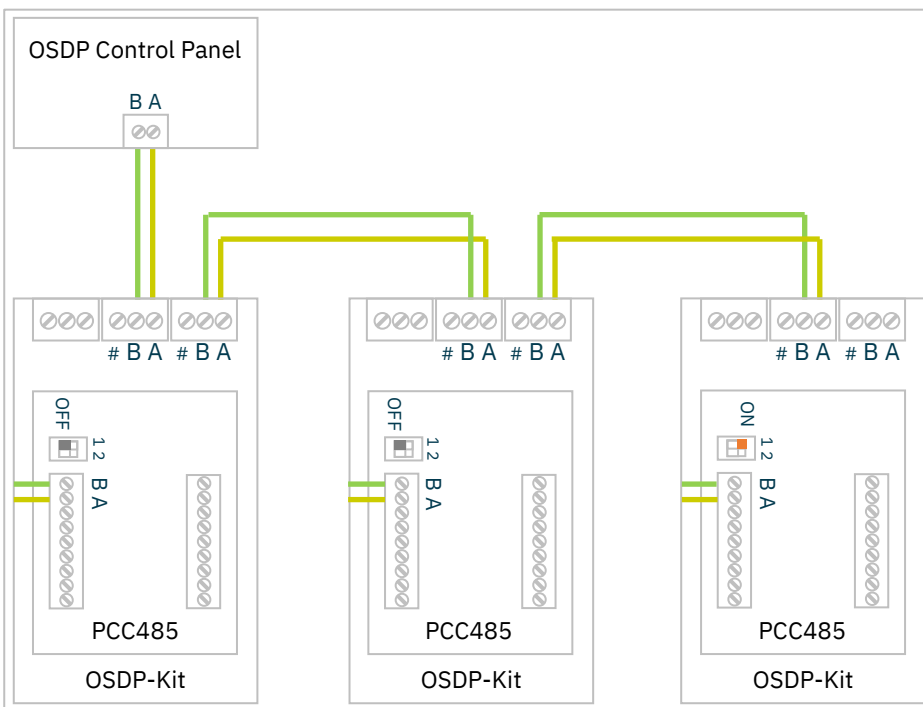

Figure 9: RS485-OSDP multi-drop wiring

For more details refer to the separate PCC485 installation guide.

3.3 TRANSIT configuration

This chapter describes how to configure the TRANSIT Ultimate reader for OSDP installations.

TRANSIT firmware requirements

The OSDP Interface Board / PCC485 requires to use one of the standard TRANSIT firmware versions, since these support the manual LED and relay control function.

- P80 v3.00 (no configuration required, use default settings)
- P81 v3.35
- P82 v3.08
- P83 v3.04
- P84 v3.06
- P85 v3.01

Newer versions are also supported as they will be backwards compatible.

Configuration settings

The relay activation and LED control must both be set to manual mode.

This is best done using the NEDAP P81TEST software. Download this software from our partner portal

<https://portal.nedapidentification.com>.

Start NEDAP P81TEST software and connect to the reader using the USB or RS232 interface.

1. Click Options, Digital I/O.
2. Disable automatic relay activation.
3. Disable automatic LED control.

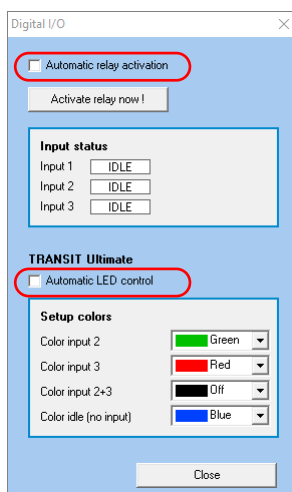

Figure 10: TRANSIT configuration for OSDP applications.

4 Connections

4.1 Overview

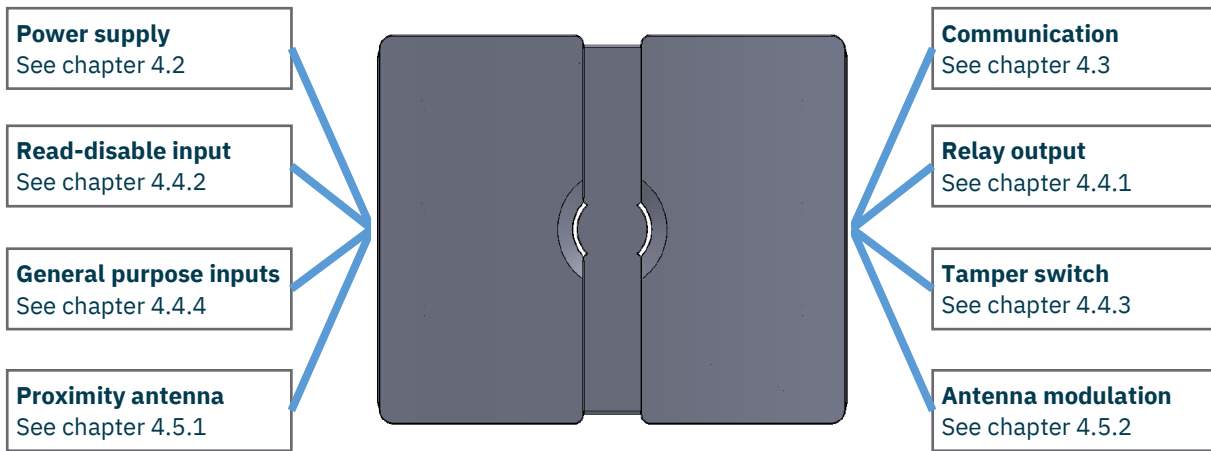

Figure 11: TRANSIT Ultimate connections overview

4.2 Power supply

The TRANSIT Ultimate can be powered by AC mains or by a 24 VDC power supply.

4.2.1 AC mains

Connect the Mains load and neutral wires to the connector terminals VAC-L and VAC-N. The earth wire should be connected to the dedicated safety ground connection.

Input voltage: 100 – 240 VAC

Frequency: 60 – 50 Hz

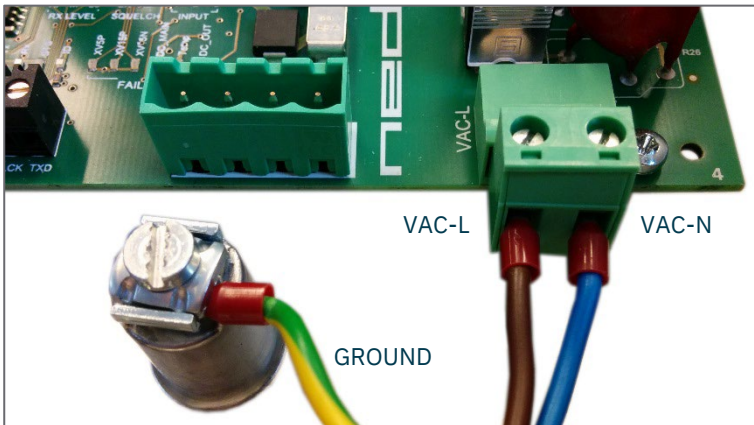

Figure 12: AC mains connections

4.2.2 DC supply input

Connect the DC power supply to the connector terminals as indicated below.

Remove the connector for easy fixing the wires.

Input voltage: 24 VDC \pm 10%

Max. input current: 700 mA @ 24 VDC

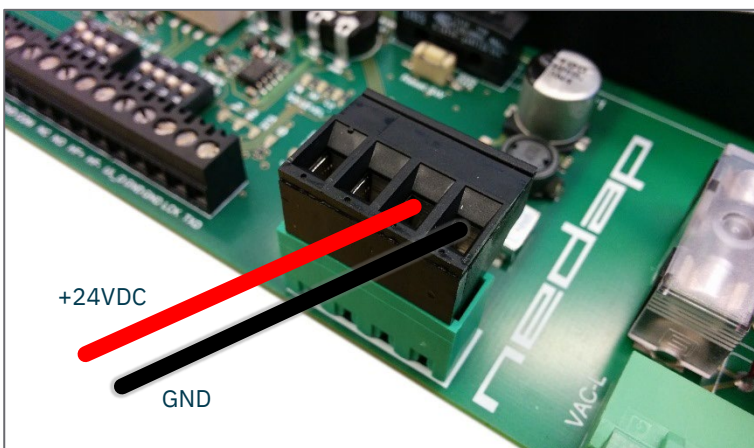

Figure 13: DC input connections

4.2.3 DC output

The DC output can be used to supply power to an additional device installed inside or near the TRANSIT Ultimate.

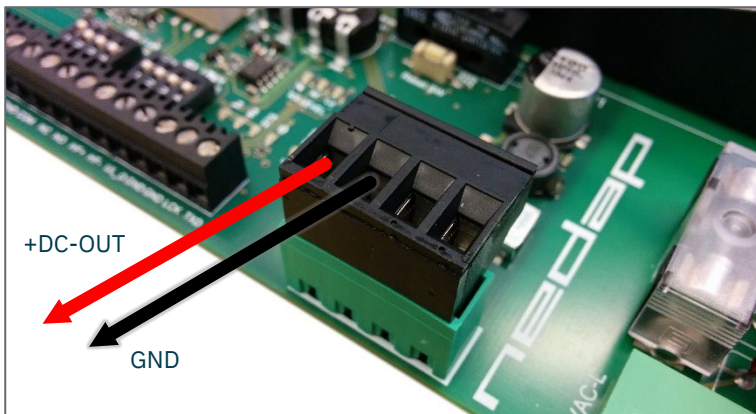

Figure 14: DC output connections

DC output ratings

Output voltage: 23.4 VDC \pm 10%

Max. output current: 100 mA.

4.3 Communication

4.3.1 USB

The TRANSIT Ultimate features an USB interface for service and installation purposes. The USB connector (Type B) is accessible behind the cover.

Note 1

While the USB interface is in use, the optional communication interface board is disabled.

Note 2:

While the USB cable is connected, it is not possible to read HID-PROX cards.

To fix this issue;

- Disconnect the USB cable
- Make sure the HID interface board is installed correctly
- Restart the TRANSIT Ultimate (or press reset button)



Figure 15: USB connection

USB driver installation

Make sure your computer is connected with internet. Connect the TRANSIT reader to your computer via the USB cable. The USB drivers may be installed automatically. In case you need to install the USB drivers manually, please go to the website www.ftdichip.com/Drivers/VCP.htm and download the VCP (Virtual Com Port) drivers. After successful installation of the USB drivers the reader will appear in the Windows device manager in "Ports (COM & LPT)" section

4.3.2 Wiegand / Magstripe / Barcode

The Wiegand, Magstripe and Barcode interfaces share the same connections. The connections are described below. The actual protocol output depends upon the reader firmware. Please refer to the firmware manual for more details.

Connections	Wiegand	Magstripe	Barcode
O-1	-	Card Loaded	-
O-2	Data-0 (green)	Clock	-
O-3	Data-1 (white)	Data	Data
GND	Ground (black)	Ground	Ground

The picture below illustrates the Wiegand wiring.

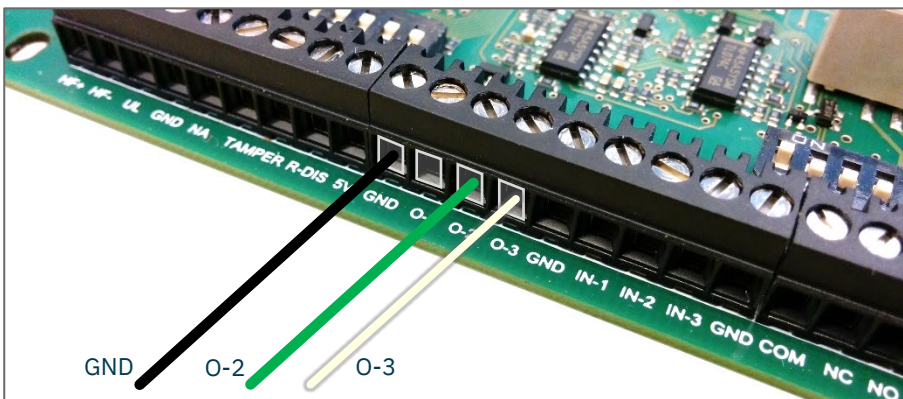

Figure 16: Wiegand wiring

Cable specification

4 x 0.25mm² shielded

Maximum cable length 150 meter.

4.3.3 RS232

An RS232 interface is available when the RS232 or HIB interface board has been installed.

TRANSIT SIDE		PC SIDE	
DIN 25	Name	DIN 9	Name
2	TXD	2	RXD
3	RXD	3	TXD
7	GND	5	GND

Cable specification

3 x 0.25mm² shielded

Maximum cable length 30 meter.

4.3.4 RS422-485

An RS422 or RS485 interface is available when the RS422-485 interface board has been installed.

SW1 selects RS422 or RS485.

SW2 enables the termination resistor. It is recommended to keep this switch in ON position.



Figure 17: RS422-485 switches.

RS422

SW1 OFF = RS422

RS422-485	RS422 HOST
TX+	RX+
TX-	RX-
RX+	TX+
RX-	TX-

RS485

SW1 ON = RS485

RS422-485	RS485 HOST
TX+	-
TX-	-
RX+	A (-)
RX-	B (+)

Cable specification

2 x 2 x 0.25mm² twisted pair shielded

Maximum cable length 1200 meter.

Warning: The RS422-485 interface board cannot be used for OSDP communication. Instead use the PCC485/OSDP converter board. See chapter 3.

4.4 Digital I/O

4.4.1 Relay output

The relay output is automatically activated upon successful identification / authentication of a transponder. The automatic-relay-activation-mode can be configured using the firmware. Please refer to the firmware manual for more details.

Authentication is only performed when Ultimate-mode is enabled. See chapter 6.3 for more details.

 By default the front cover LED lights-up simultaneously with the relay output. This might be changed by enabling manual relay/led activation mode. See for more details firmware manual.

Connections

NO	Relay contact normally open
NC	Relay contact normally closed
COM	Relay contact common

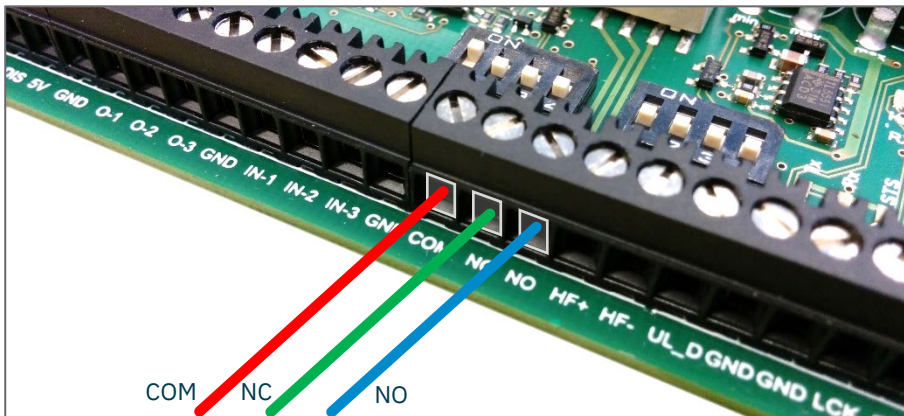

Figure 18: Relay output connections

Contact ratings

Max. switching current:	2A
Max. switching voltage:	24VDC
Max. switching power:	50W

OSDP

In OSDP operation, the relay output is set with command OSDP_OUT output #0.

4.4.2 Read disable input

The reading of the TRANSIT Ultimate can be stopped with the read disable input (RDIS). This input is commonly used in combination with a sensor (e.g. inductive loop) that detects the presence of a person or vehicle. Use a potential-free contact (relay) to connect the internal 5V to the RDIS input. Leave open or unconnected when reading should be enabled.

Connections

R-DIS Read disable input
5V Internal 5V source for read disable input.

Warning: using an external 5V supply could damage the reader.

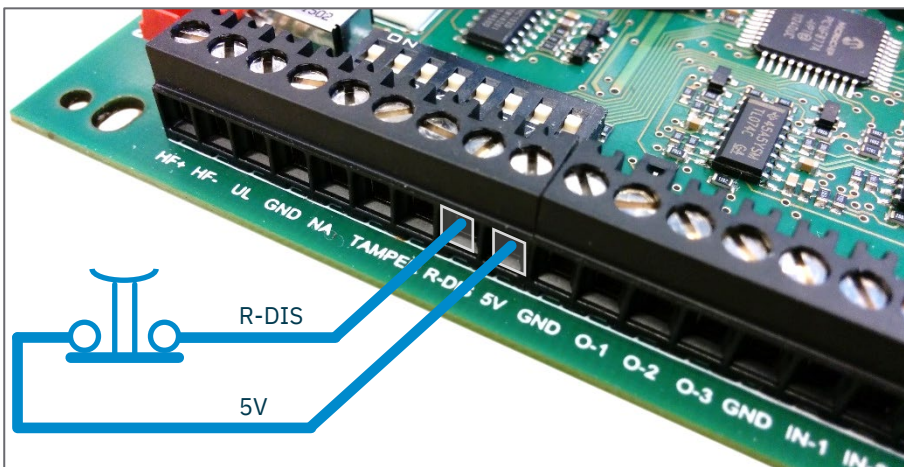

Figure 19: Read disable input

4.4.3 Tamper switch

The TRANSIT Ultimate features an internal tamper switch that indicates when the cover is opened. This contact may be connected to an external alarm system. The contacts are normally closed when the cover is in place. Tamper switches of multiple TRANSIT Ultimate readers may be connected in series.

Connections

TAMPER Tamper switch contacts (normally closed)
TAMPER “

Contact ratings

Max. switching current: 50 mA (0.5V voltage drop)
Max. switching voltage: 24 VDC

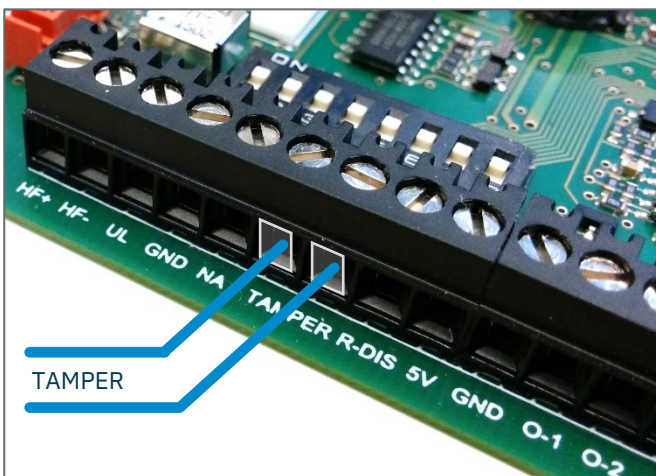

Figure 20: Tamper switch

OSDP

The tamper switch status will NOT be reported through OSDP messages.

4.4.4 General purpose inputs

Three general purpose inputs are available on the TRANSIT Ultimate. The inputs are active low. No external voltage should be applied to the inputs. Connect to ground using a potential-free contact (relay) to activate. Leave open or unconnected when not used or inactive.

Depending upon the used firmware version, these inputs optionally can be used to activate the relay or control the front-cover 3-color LED. See for more details the firmware guide.

Connections

IN-1	General purpose input 1
IN-2	General purpose input 2
IN-3	General purpose input 3
GND	Ground

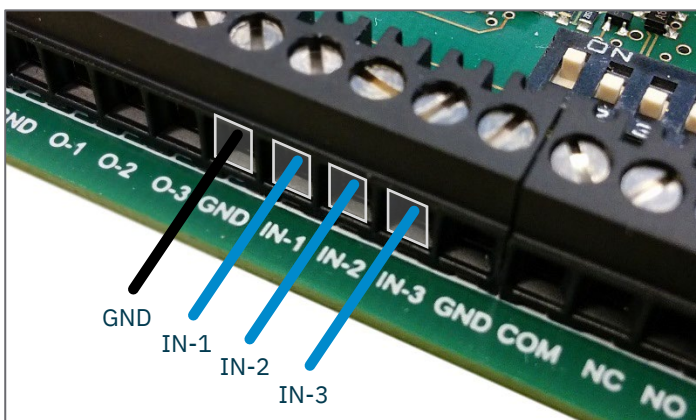

Figure 21: GPIO inputs

OSDP

In OSDP operation, these inputs are used to control the relay output and the front cover LED. See for more details chapter 3.

4.5 Special connections

4.5.1 Proximity antenna

Optionally a NEDAP proximity antenna can be connected to the TRANSIT Ultimate to enable simultaneously long-range and proximity identification. This is useful when controlling a gate where vehicles as well as pedestrians, cyclists and/or motorists can enter. The antenna can be either a NEDAP low-frequency proximity antenna or a NEDAP reader with antenna modulation output (e.g. NVITE or uPASS Access).

Connections

HF+	Antenna+
HF-	Antenna- (cable shield)
UL	Green LED output (max. 18mA)
GND	Ground for LEDs
NA	Red LED output (max. 18 mA)

Cable specification

4 x 0.25mm² shielded

Maximum cable length 15 meter

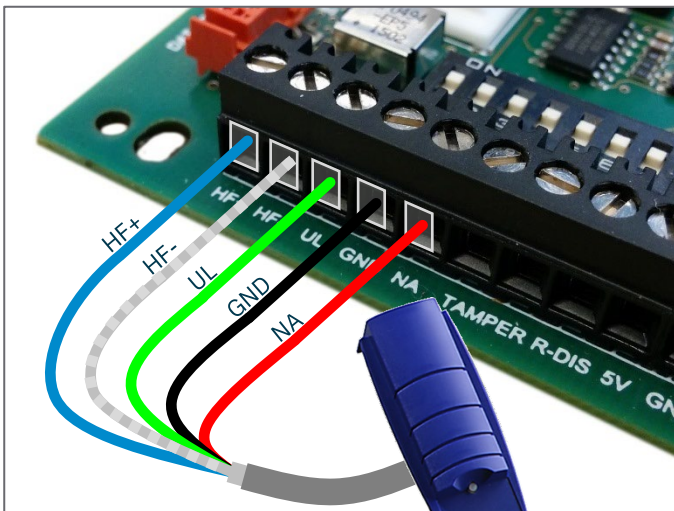

Figure 22: Proximity antenna connections

Notes

- While using the proximity antenna no authentication or other Ultimate functions are performed.
- The LED outputs can drive external LEDs (and not activate digital inputs, for example on the uPASS Access).
- SW1-8 must be in the OFF position to enable this function. See chapter 6 for dip-switch location.

4.5.2 Nedap antenna modulation

The Nedap antenna modulation interface is used to connect the TRANSIT Ultimate to the PCC485 OSDP protocol converter. See chapter 3.

Alternatively the Nedap antenna modulation interface can also be used to connect the TRANSIT Ultimate to NEDAP AEOS access control hardware such as the AP1001.

Connections

MHF+ Antenna modulation output, connect to PCC485 HF+ or (AP1001 ANT).

MHF- Antenna modulation ground (cable shield), connect to PCC485 HF- (or AP1001 ANT GND).

Cable specification

Coax RG58U

Maximum cable length 100 meter

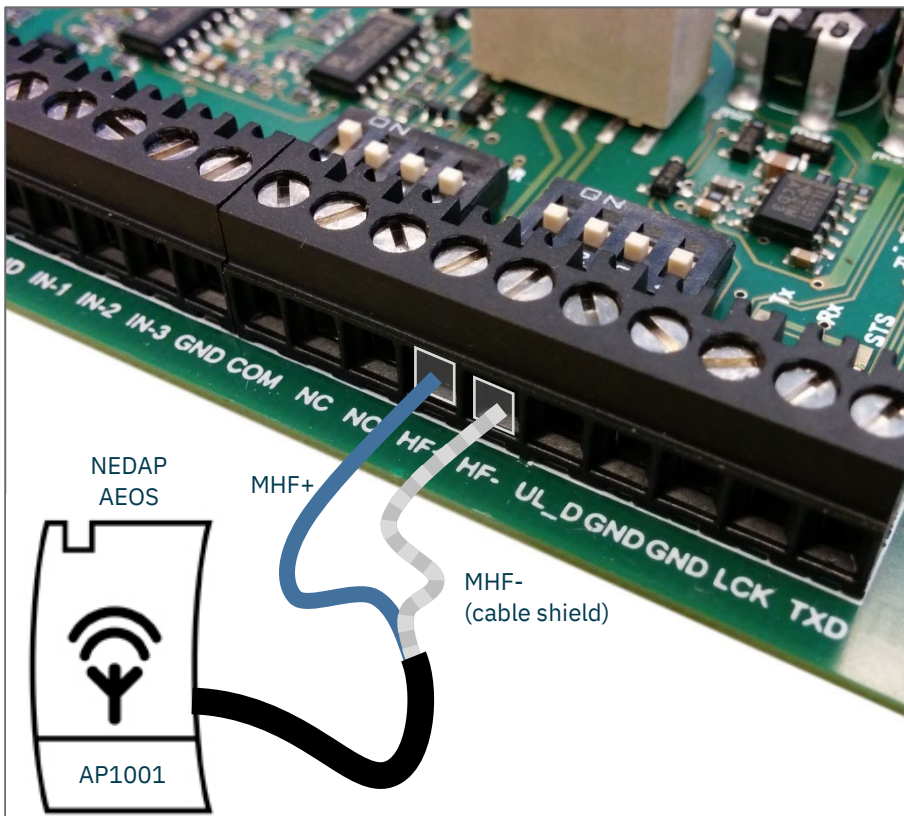

Figure 23: Antenna modulation connection

5 Firmware update

The TRANSIT Ultimate supports the same firmware versions as the TRANSIT Standard. Different firmware versions are available to support different features and communication protocols. For each firmware version a separate manual is available.

The firmware can be changed or updated using the TRANSIT Firmware Upgrade software tool.

Firmware update procedure

- Start TRANSIT Firmware Update (PICLOAD) software.
- Select communication port (e.g. COM1).
- Select the firmware (e.g. P61, P81 or P84).
- Click Download and wait until completed.

If the message "searching for bootloader ..." does not disappear, then preset the reset-switch on the TRANSIT main board. Make sure that the serial communication select switch is set to TRANSIT (PIC). See chapter 6.1.

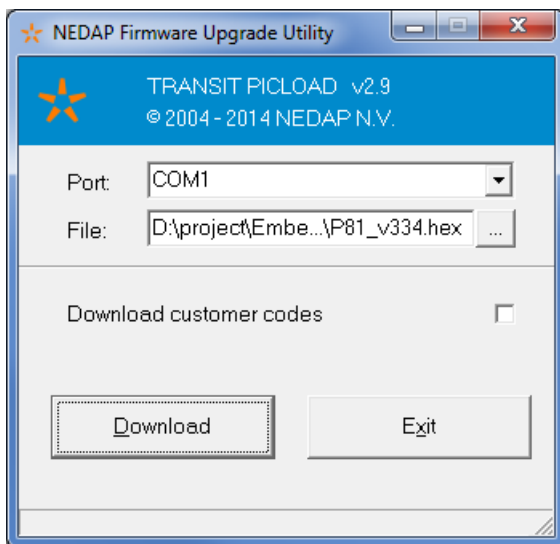

Figure 24: TRANSIT Firmware Upgrade Utility

6 Configuration

The TRANSIT Ultimate has different dip-switches to select configuration settings. Figure 25 shows the default dip-switch settings and their location.

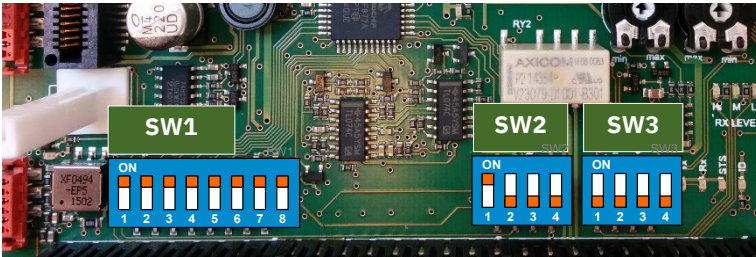

Figure 25: Dip-switch locations

The switches SW1 are used to select various options within the actual loaded firmware. For example, to select the serial baud rate, wiegand output options, etc. Refer to the specific firmware manual for details.

The next chapters will describe the function of the switches SW2 and SW3.

6.1 Serial communication select

By default the USB or communication interface board connections will allow communication with the TRANSIT processor (PIC). The communication protocol is determined by the TRANSIT firmware.

The USB or communication interface board connections can also be used to communicate with the processor located on the TAB board. This is for test purposes and will not further be explained in this manual. Note that while the USB cable is connected, the communication interface board is disabled.

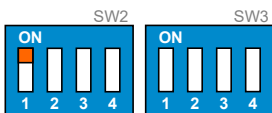

TRANSIT communication (PIC)

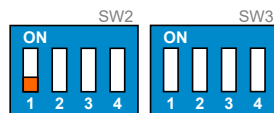

Test communication (TAB)

6.2 Range beeper

Enable or disable the internal range beeper. The beeper indicates transponder identification. The signal strength of the identified transponder determines the beeping frequency. When the transponder is near to the reader the range beeper will beep fast

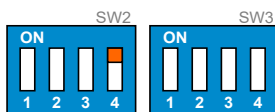

Range beeper ON

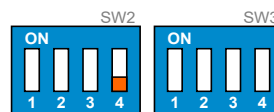

Range beeper OFF

6.3 Ultimate mode

The TRANSIT Ultimate can operate in the ULTIMATE-mode or in the NORMAL-mode.

In the NORMAL-mode the reader will skip the secure authentication (the TAB board is bypassed). In this mode the reader is backwards compatible with the TRANSIT Standard and can read original tags, such as the Compact-Tag, Window-Button, Heavy-Duty-Tag and Boosters. Also the Ultimate-tags will work, but no authentication is performed.

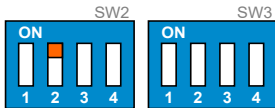

ULTIMATE-mode

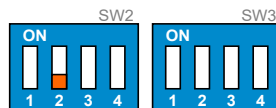

NORMAL-mode (TAB bypass)

In the ULTIMATE-mode the TRANSIT will perform a secure authentication on Ultimate-tags. This requires the Security Key Pack to be installed.

In ULTIMATE-mode the TRANSIT also supports reading HID SEOS or iCLASS cards in the Smartcard-Booster End2End. This requires TAB board hardware revision C.

See chapter 2.4 for more details about installation of Security Key Pack and how to identify TAB hardware revision.

Standard tags

Window-Button, Compact-Tag, Heavy-Duty-Tag, Prox-Booster, Smartcard-Booster 2G, etc.

Yes, can read in NORMAL-mode

Yes, can read in ULTIMATE-mode, but only with TAB hardware revision C and Security Key Pack is **not** installed.

Ultimate tags

Smartcard-Booster Ultimate, Window-Tag Ultimate

Yes, can read in NORMAL-mode, but secure-authentication is skipped.

Yes, can read in ULTIMATE-mode, but only if Security Key Pack is installed.

Transparent tags

Smartcard-Booster End2End (SEOS)

Yes, can read in ULTIMATE-mode, but only with TAB hardware revision C.

6.4 Frequency select

The TRANSIT Ultimate reader operates in the 2.45GHz ISM frequency band.

When two or more readers are within a range of 15 meters (50 feet), these readers should be set on a different operating frequency.

It may also be required to select a different frequency to avoid disturbance between the TRANSIT Ultimate and other 2.45GHz equipment, such as Wi-Fi access points.

Please also read chapter 6.6 when experiencing interference.

The frequency channel is selected on the transceiver board which is located in the front cover of the reader. Select the frequency channel using a display & push-buttons (see chapter 6.4.1) or using dip-switches (see chapter 6.4.2).

The TAB board operates at 433 MHz. It uses 2 fixed frequency channels. This cannot be changed.

6.4.1 Frequency select display & buttons

Only for TRANSIT Ultimate FCC ID: CGDTRANSITULT2 (IC: 1444A-TRANSITULT2)

Press the RST button to activate the display. The display value indicates the currently selected frequency. The display will automatically switch off after 60 seconds.

Press UP/DOWN to select a frequency. Lookup the display value in appendix B.

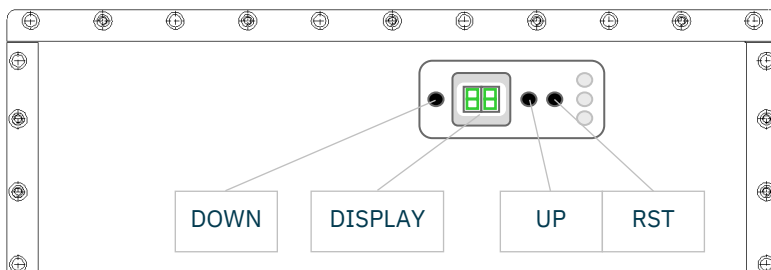

6.4.2 Frequency select dip-switches

Only for TRANSIT Ultimate FCC ID: CGDTRANSITULTI (IC: 1444A-TRANSITULTI)

Select a frequency channel using the dip-switches located on the transceiver board in the front cover of the reader. Refer to frequency selection table appendix B.

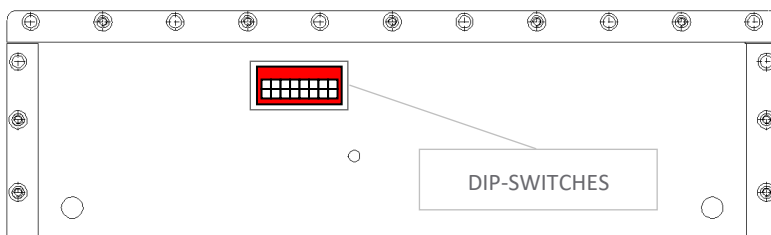

6.5 Read range control

The read range of the TRANSIT Ultimate can be controlled with the embedded squelch function. The squelch references the received signal strength against the squelch level threshold. When the received signal strength is below the squelch threshold level no identification is possible. The received signal strength becomes higher when the transponder comes closer to the reader. When the received signal strength exceeds the squelch threshold level the transponder will be identified.

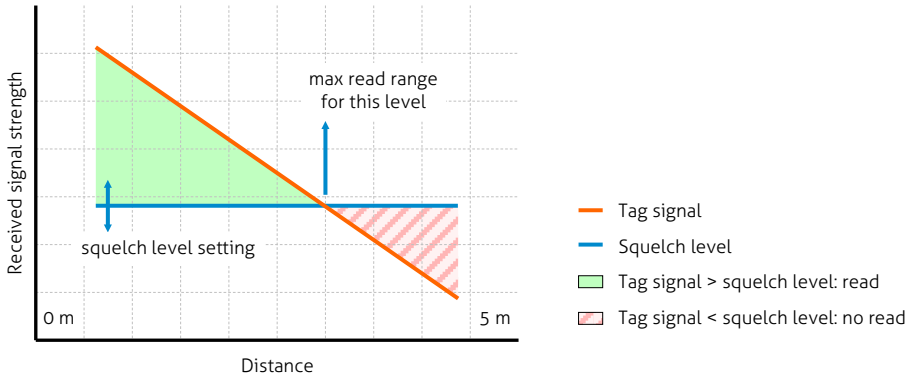

Figure 26: Squelch principle

Adjustment of the read range is done by enabling the squelch and setting the squelch level with its potentiometer.

For maximum read range, disable the squelch completely with the enable/disable squelch switch.

LED SQ-ACT is on to indicate that the squelch is enabled.

LED SQ-ACT is on when the transponder signal is below the squelch level (red area in Figure 26).

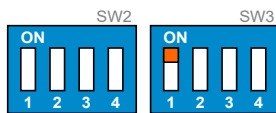

Squelch enabled

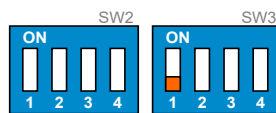

Squelch disabled (max. read range)

- ↻ SQ-Level potentiometer clockwise → Long read range.
- ↻ SQ-Level potentiometer counter-clockwise → Short read range.

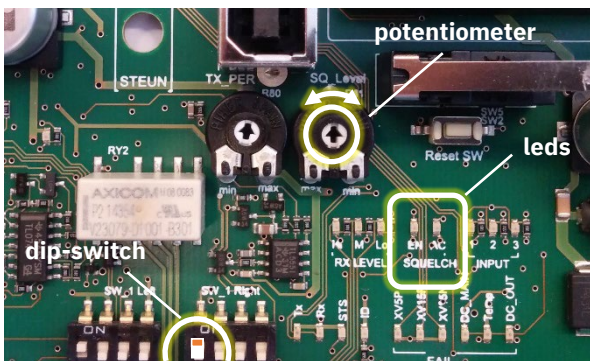

Figure 27: Squelch controls

6.6 Microwave time-sharing

The microwave antenna of the TRANSIT Ultimate is continuously on. This will ensure the fastest identification. However it may cause interference on other 2.45GHz equipment.

Enable the microwave time-share mode to only use the selected frequency periodically (the reader automatically switches on and off). During the periods that the TRANSIT reader is off, other equipment can use the same frequency undisturbed.

The reader will be on for 300 milliseconds, which is long enough for a reliable identification of a tag. The off-time is between 0.5 and 5 seconds. This is configurable with the TX-PER potentiometer.

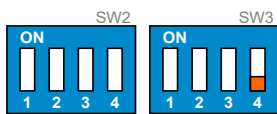

Microwave continuously-on

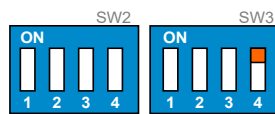

Microwave time-share (periodically on)

- ↻ TX-PER potentiometer counter-clockwise → Short off (500 msec).
- ↻ TX-PER potentiometer clockwise → Long off (5000 msec).

To avoid disturbance or interference you can also try to select an unused frequency channel. See chapter 6.4.

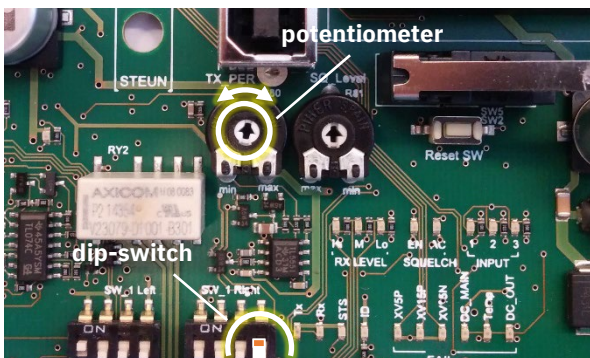

Figure 28: Microwave time-sharing controls

7 LED indications

7.1 Main board LED indications

A number of LEDs on the main board of the TRANSIT Ultimate indicate the status of the reader. The list below describes the function of each LED.

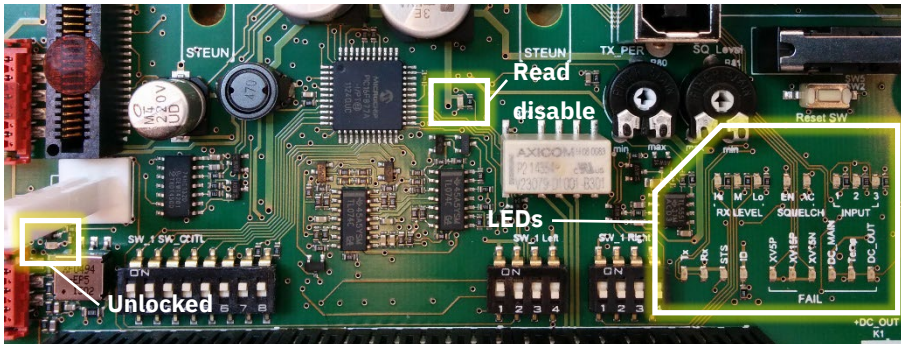

Figure 29: LED indications main board

Led	Description
●●● RX_LEVEL	LED bar indicating the received tag signal strength. This LED bar also indicates the presence of radio interference. In case of interference, try switching to a different frequency. See chapter 6.4.
● SQ-EN	Squelch enabled. Reduced read range. See chapter 6.5.
● SQ-ACT	Squelch active. Tag signal below squelch threshold level.
● INPUT-1	Input 1 status. On when contact is closed. See chapter 4.4.4.
● INPUT-2	Input 2 status. On when contact is closed.
● INPUT-3	Input 3 status. On when contact is closed.
● Tx	Transmit serial data (USB, I/F-board). See chapter 4.3.
● Rx	Receive serial data (USB, I/F-board).
● STS-LED	TRANSIT firmware status LED (PIC) Slow blinking: Heartbeat (0.8s on / 0.8s off) Fast blinking: Boot loader active. Indicated after restart. Twice blinking: Configuration menu active. Off: Abnormal situation.
● ID-LED	TRANSIT identification. Blinks fast upon valid tag. When no identification check dip-switches and customer-code.
● FAIL-XV5P	Power supply failure +5V.
● FAIL-XV15P	Power supply failure +15V.
● FAIL-XV15N	Power supply failure -15V.
● FAIL-DC_MAIN	Power supply failure DC-MAIN.
● FAIL-Temp	Temperature critically high.
● FAIL-DC_OUT	DC OUTPUT overload. See chapter 4.2.3.
● Unlocked	PLL unlocked. Check flat cable connections. Try switching to a different frequency. See chapter 6.4.
● Read disable	Read disable LED. On when RDIS input active and reading disabled. See chapter 4.4.2.

7.2 TAB board LED indications

The LEDs on the TAB board indicate its status. These LEDs are very useful when troubleshooting the Ultimate-mode features. Below the function of each LED is described.

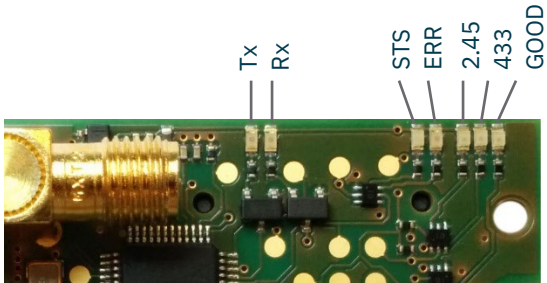

Figure 30: LED indications TAB board

Led	Description
● STS	TAB board status LED Fast blink: Starting up. Regular blink: Status OK. Authentication required. Double blink: Status OK. HID only. Special blink 1: Programmer firmware (0.1s on / 0.9s off). Special blink 9: TAB stopped. Hardware fault, (0.9s on / 0.1s off).
● ERR	Error LED. Should normally be off.
● 2.45	2.45GHz microwave tag data received. Does not indicate when TAB bypassed. See chapter 6.3.
● 433	433MHz tag data received. Only indicated when using Ultimate tags.
● GOOD	Smartcard-Booster Ultimate authenticated successful. Smartcard-Booster End2End card read successful.

A Technical specification

Technical specification	TRANSIT Ultimate
Power supply	100 – 240 VAC (60 – 50 Hz) or 24 VDC (± 10%)
Power consumption	< 25 VA (AC), < 20 W (DC)
Power output	24Vdc, 0.1A
Dimensions	330 x 274 x 140 mm
Weight	5 kg
Housing	Cover: ABS, Housing: Die-cast ADC12
Protection	IP66, outdoor use
Operating temperature	-30°C – +60°C
Maintenance	Transit Ultimate is free of regular maintenance
Detection range	Up to 15 meters (with Window-Button), message acceptance ratio > 80%
Object speed	Up to 200 km/h at appropriate distance (*)
Operating frequency	2.438 – 2.457 GHz, 433.62 & 434.22 MHz (RX_CAT_3); Ton < 5 sec
Frequency channels 2.45GHz	48 FCC channels, 14 ETSI channels, 600k Hz spacing
Polarization 2.45 GHz	Circular (LHC)
Polarization 433 GHz	Horizontal
Air interface 2.45 GHz	Nedap proprietary encryption standard 1.875 kbps; integrated antenna
Air interface 433 MHz	Encryption based upon diversified AES128 keys. 300 kbps; GFSK - 75kHz; dedicated antenna Duty cycle < 1%; LBT not applicable
Relay output	1 relay output (NO, common, NC), 24 VDC 2A
Inputs	3 dry contact
Audio	Range check beeper
Antenna input	External inductive proximity antenna connection 120kHz
Antenna output	Nedap external reader antenna connection 120kHz output
Interfaces	USB, Wiegand, Magstripe, Barcode (*).
Optional interface boards:	RS232, RS422, RS485, TCP/IP (*).
Communication protocols	Various, including CR/LF, DC2/DC4 and OSDP.
Mounting	Wall Mounting Set included, optional Pole Mounting Kit available.
Certifications:	
EMC	EMC Directive EC : 2014/30/EC ; 2004/108/EC EN301 489-1,-3,-17 ; EN61000-6-2 ; EN61000-6-3
Regulations	FCC part 15.245; EN 300 440 (2.45 GHz) FCC part 15.231a,-b ; EN 300 220 (433 MHz)
UL294 6th ed.	Access Control Performance Line security: Level 1 Destructive attack: Level 1 Endurance: Level 4 Standby Power: Level 1
	The TRANSIT Ultimate reader must be connected and controlled by a UL listed controller (e.g. AP4803X).

(*) not evaluated by UL

B Frequency channels

Frequency channel selection table:

Display value	Frequency (GHz)	SW1	SW2	SW3	SW4	SW5	Wi-Fi	ETSI	FCC
4C	2.4360	-	-	-	-	-		-	✓
4D	2.4366	-	-	-	-	-		-	✓
4E	2.4372	-	-	-	-	-	CH6	-	✓
4F	2.4378	-	-	-	-	-		-	✓
50	2.4384	ON	ON	ON	ON	ON		-	✓
51	2.4390	OFF	ON	ON	ON	ON		-	✓
52	2.4396	ON	OFF	ON	ON	ON		-	✓
53	2.4402	OFF	OFF	ON	ON	ON		-	✓
54	2.4408	ON	ON	OFF	ON	ON		-	✓
55	2.4414	OFF	ON	OFF	ON	ON		-	✓
56	2.4420	ON	OFF	OFF	ON	ON	CH7	-	✓
57	2.4426	OFF	OFF	OFF	ON	ON		-	✓
58	2.4432	ON	ON	ON	OFF	ON		-	✓
59	2.4438	OFF	ON	ON	OFF	ON		-	✓
5A	2.4444	ON	OFF	ON	OFF	ON		-	✓
5B	2.4450	OFF	OFF	ON	OFF	ON		-	✓
5C	2.4456	ON	ON	OFF	OFF	ON		-	✓
5D	2.4462	OFF	ON	OFF	OFF	ON		✓	✓
5E	2.4468	ON	OFF	OFF	OFF	ON		✓	✓
5F	2.4474	OFF	OFF	OFF	OFF	ON	CH8	✓	✓
60	2.4480	ON	ON	ON	ON	OFF		✓	✓
61	2.4486	OFF	ON	ON	ON	OFF		✓	✓
62	2.4492	ON	OFF	ON	ON	OFF		✓	✓
63	2.4498	OFF	OFF	ON	ON	OFF		✓	✓
64	2.4504	ON	ON	OFF	ON	OFF		✓	✓
65	2.4510	OFF	ON	OFF	ON	OFF		✓	✓
66	2.4516	ON	OFF	OFF	ON	OFF		✓	✓
67	2.4522	OFF	OFF	OFF	ON	OFF	CH9	✓	✓
68	2.4528	ON	ON	ON	OFF	OFF		✓	✓
69	2.4534	OFF	ON	ON	OFF	OFF		✓	✓
6A	2.4540	ON	OFF	ON	OFF	OFF		-	✓
6B	2.4546	OFF	OFF	ON	OFF	OFF		-	✓
6C	2.4552	ON	ON	OFF	OFF	OFF		-	✓
6D	2.4558	OFF	ON	OFF	OFF	OFF		-	✓
6E	2.4564	ON	OFF	OFF	OFF	OFF		-	✓
6F	2.4570	OFF	OFF	OFF	OFF	OFF	CH10	-	✓
70	2.4576	-	-	-	-	-		-	✓
71	2.4582	-	-	-	-	-		-	✓
72	2.4588	-	-	-	-	-		-	✓
73	2.4594	-	-	-	-	-		-	✓
74	2.4600	-	-	-	-	-		-	✓
75	2.4606	-	-	-	-	-		-	✓
76	2.4612	-	-	-	-	-		-	✓
77	2.4618	-	-	-	-	-	CH11	-	✓
78	2.4624	-	-	-	-	-		-	✓
79	2.4630	-	-	-	-	-		-	✓
7A	2.4636	-	-	-	-	-		-	✓
7B	2.4642	-	-	-	-	-		-	✓

The selected frequency must comply with local radio regulations.

ETSI frequency range from 2.446 to 2.454 GHz.

FCC frequency range from 2.435 to 2.465 GHz.

C Nedap part numbers

Product	Part number	Description
	9215689	TRANSIT Ultimate
	9216537	Security Key Pack (SAM)
	5626595	Pole Mounting Kit
	9218327	Weather Protection Hood
	9229078	OSDP Installation Board (includes PCC485)
	7819102	HID interface board (HIB)
	7817940	TCP/IP interface board
	7817347	RS422-485 interface board
	7806434	RS232 interface board
	9564314	Window Tag Ultimate
	9982809	Smartcard Booster Ultimate
	9982817	LEGIC Booster Ultimate

D Disposal of equipment

The products will be disposed of by the end-user and discharge Nedap for any liability or responsibility thereof.



The WEEE symbol in Europe indicates that the relevant electrical product or battery should not be disposed of as general household waste in Europe. To ensure the correct waste treatment of the product and battery, please dispose them in accordance to any applicable local laws of requirement for disposal of electrical equipment or batteries. In so doing, you will help to conserve natural resources and improve standards of environmental protection in treatment and disposal of electrical waste (Waste Electrical and Electronic Equipment Directive WEEE 2012/19/EU).

E CE / UKCA declaration

Hereby NEDAP N.V. declares that the subject equipment is in compliance with:

- For CE: Directives 2014/53/EU (Radio Equipment Directive) and 2011/65/EU (Restriction of the use of certain hazardous substances).
- For UKCA: SI2017/1206 (UK Radio Equipment Regulations 2017) and SI2012/3032 (Restriction of the Use of Certain Hazardous Substances in Electrical and Electronic Equipment Regulations 2012 (RoHS)).

The full text of the declarations of conformity is available at <https://portal.nedapidentification.com> where, if applicable, also REACH information can be found.

F FCC / IC statement

FCC ID: CGDTRANSITULT2
IC: 1444A-TRANSITULT2

FCC ID: CGDTRANSITULTI
IC: 1444A-TRANSITULTI

Compliance statements (part 15.19)

This device complies with part 15 of the FCC Rules and to RSS210 of Industry Canada. Operation is subject to the following two conditions:

- (1) this device may not cause harmful interference, and
- (2) this device must accept any interference received, including interference that may cause undesired operation.

Cet appareil se conforme aux normes CNR210 exemptés de licence du Industry Canada.

L'opération est soumise aux deux conditions suivantes:

- (1) cet appareil ne doit causer aucune interférence, et
- (2) cet appareil doit accepter n'importe quelle interférence, y inclus interférence qui peut causer une opération non pas voulu de cet appareil.

Warning (part 15.21)

Changes or modifications not expressly approved by party responsible for compliance could void the user's authority to operate the equipment. This in particular is applicable for the antenna which can be delivered with the TRANSIT ULTIMATE System.

RF Exposure (OET Bulletin 65)

To comply with FCC RF exposure requirements for mobile transmitting devices, this transmitter should only be used or installed at locations where there is at least 20cm separation distance between the antenna and all persons.

Information to the User (Part 15.106(b))

Note: This equipment has been tested and found to comply with the limits for a class B digital devices, pursuant to part 15 of the FCC Rules. These limits are designed to provide reasonable protection against harmful interference in a residential installation. This equipment generates, uses and can radiate radio frequent energy and, if not installed and used in accordance with the instructions, may cause harmful interference to radio communications. However, there is no guarantee that interference will not occur in a particular installation. If this equipment does not cause harmful interference to radio or television reception, which can be determine by turning the equipment off and on, the user is encouraged to try to correct the interference by one or more of the following measures:

- Reorient or relocate the receiving antenna.
- Increase the separation between the equipment and receiver.
- Connect the equipment into an outlet on a circuit different from that to which the receiver is connected.
- Consult the dealer or an experienced radio/TV technician for help.

G Document revision

Version	Date	Comment
5.11	2023-06-21	HR: updated TAB hardware rev C
5.10	2022-11-04	HR: added UKCA
5.09	2021-03-19	HR: updated installation guidelines
5.08	2020-05-13	HR: updated OSDP Installation Board
5.07	2020-04-22	HR: minor updates
5.06	2020-04-10	HR: added OSDP-Kit
5.05	2019-05-08	HR: updated antenna modulation
5.04	2018-07-12	HR: removed profibus (obsolete)
5.03	2018-05-23	HR: added remarks when using USB interface
5.02	2018-05-02	GSA: Added remarks concerning positioning during mounting
5.01	2017-09-08	HR: updates for changed transceiver board
4.10	2017-07-17	HR: added outdoor use statement
4.09	2016-10-06	HR: added time sharing chapter
4.08	2016-08-08	HR: weather protection hood added
4.07	2016-01-14	HR: wall mounting set updated
4.06	2015-12-17	HR: update for UL certification
4.05	2015-08-25	HR: update for compliance certification
4.04	2015-08-25	HR: mounting sets naming unambiguous
4.03	2015-07-22	HR: updated dip-switch
4.02	2015-06-09	HR: updated technical specifications
4.01	2015-06-01	HR: updated frequency channel table
4.00	2015-04-10	HR: Initial version